

Built Right and On-Time...Every Time!

AMC
APPLIED MOTOR CONTROLS

Phone: 1-866-524-1055

Fax: 1-210-524-1044

www.amclp.com

Catalog ICP-A11

UL Listed Pump Control Panels



Applied Motor Controls builds custom-designed and standard Motor Starters and Control Panels for use in water and wastewater pump applications.

Since 2003, our reliable products have been protecting and controlling pumps in the following applications: Industrial, Municipal, Irrigation and Commercial.

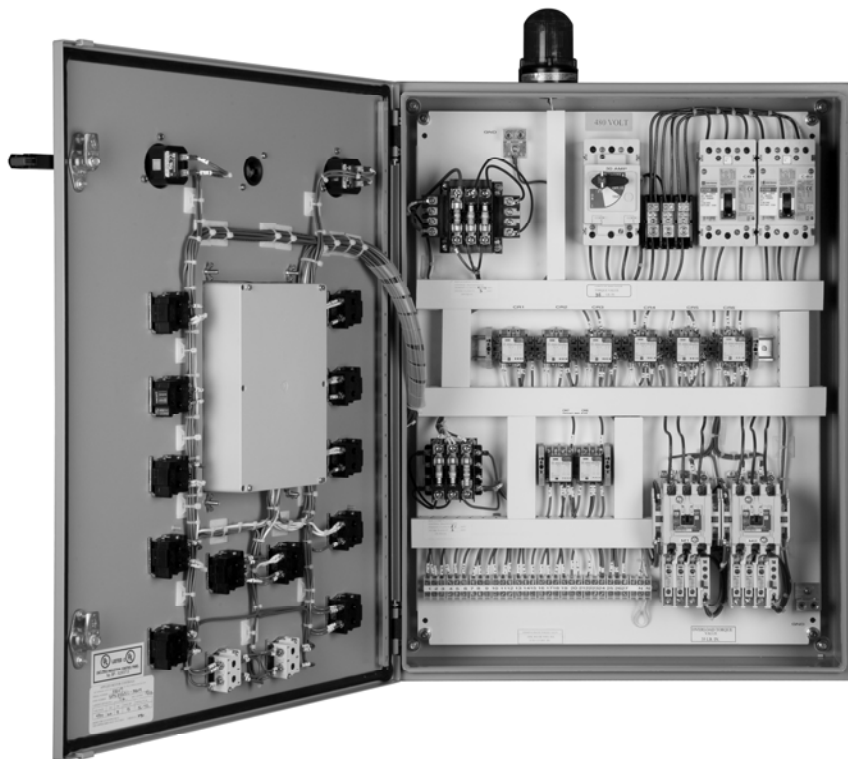

As an independent builder of industrial controls panels, we offer our customers the capability of integrating power and control products from several brands.

All of our products bear the UL 508 Listed Industrial Controls label, and are built to the highest and latest standards of quality, reliability, and safety.

Built Right and On-Time...Every Time!



Terms & Conditions of Sale

Applied Motor Controls (hereinafter called "Seller") agrees to sell the goods covered herein on the following terms and conditions of sale. Any additional or different terms that may be contained in any documents furnished by the Buyer are hereby objected to and rejected.

Buyer's acceptance of the Goods will manifest Buyer's assent to these terms and conditions.

1. **Warranty:** The Seller warrants its products and equipment to be free from defects in material and workmanship. If within ONE YEAR FROM DATE OF START UP, BUT NO MORE THAN TWO YEARS FROM DATE OF SHIPMENT from Seller's factory, any failure to conform with this warranty appears within such time, Seller shall, if given prompt notice by Buyer, correct such non-conformity either by repair or replacement of the non-conforming product or part, F.O.B. repair facility.

The seller is not responsible for damage to its products through normal wear and tear, improper installation, unauthorized alterations or repairs, lack of proper maintenance, improper use, or attempts to operate outside its rated capacity.

2. **Orders:** Orders are subject to acceptance at home office of the Seller

3. **Payments:** Payment is due in full 30 days from date of shipment. Seller may require full or partial payment in advance if, in its sole judgment, the financial condition of the Buyer does not merit terms of payment specified. If the Buyer fails to pay any invoice when due, Seller may defer delivery. A service charge, the lesser of the highest allowed by law or 1.5% per month, or fraction thereof, for a maximum of 18% per annum will be charged on all past-due invoices.

4. **Prices:** Prices are subject to change without notice. Prices will be the prices in effect at the time of shipment by Seller. In the event of a price change, the effective date of the change will be the date shown on the new price discount sheets.

5. **Taxes:** Prices do not include any taxes. In the event Seller is required to pay any taxes, the Buyer shall reimburse Seller therefore, unless Buyer provides Seller at the time an order is submitted with exemption certificates or other documents acceptable to taxing authorities.

6. **Shipments and Delivery:** Shipments are made F.O.B. Seller's shipping point. All material is carefully packed for shipment. Risk of loss or damage and responsibility shall pass from Seller to Buyer upon delivery. While Seller will use reasonable efforts to maintain delivery dates acknowledged or quoted by Seller, all shipping dates are approximate and not guaranteed. Seller reserves the right to make partial shipments.

7. **Returns for Credit:** No returns for credit shall be accepted unless Seller's written permission has been obtained in each case in advance. Only standard products from Seller's regular line which are in active demand can be accepted for credit. Credits shall not be issued for custom-built or modified products. Credit amount will be based on invoiced price, subject to reasonable deduction for handling and restoration of goods to salable condition.

8. **Limitation of Liability:** Buyer agrees that in no event shall Seller's liability to buyer and/or its customers tend to include incidental, consequential, or punitive damages. The term "consequential damages" shall include, but not limited to, loss of anticipated profits, loss of use, loss of revenue, cost of capital, and damage or loss of other property or equipment.

9. **Errors:** All clerical errors are subject to corrections

10. **Effective Date:** January 1, 2008



Alphabetical Index

Contents	Page
Across-the-Line Pump Control Panels – Description & Features	5
Across-the-Line Pump Control Panels – List Prices – 230V/1-Phase	6
Across-the-Line Pump Control Panels – List Prices – 208/230/460V/3-Phase	7, 8
Auto-Transformer Pump Control Panels – Description & Features	11
Auto-Transformer Pump Control Panels – List Prices	12
Duplex Booster Pump Control Panels – Description & Features	19
Duplex Booster Pump Control Panels – List Prices	20
Duplex Booster Pump Control Panels – Options	21, 22
Duplex Lift Station Pump Panels – Description & Features	27
Duplex Lift Station Pump Panels – List Prices	28
Duplex Lift Station Pump Panels – Options	29, 30
Factory-Installed Modifications for Pump Panels & Motor Starters	17, 18

Alphabetical Index

Contents	Page
Magnetic Motor Starters – Description & Features	1
Magnetic Motor Starters – List Prices – 230V/1-Phase	2
Magnetic Motor Starters – List Prices – 208/230/460V/3-Phase	3, 4
Part-Winding Pump Control Panels – Description & Features	9
Part-Winding Pump Control Panels – List Prices	10
Simplex Lift Station Pump Panels – Description & Features	23
Simplex Lift Station Pump Panels – List Prices	24
Simplex Lift Station Pump Panels – Options	25, 26
Solid State Soft Start Pump Control Panels – Description & Features	13
Solid State Soft Start Pump Control Panels – List Prices	14
Technical Information	31 – 34
Wye-Delta Open-Transition Pump Control Panels – Description & Features	15
Wye-Delta Open-Transition Pump Control Panels – List Prices	16

Product Description

Full Voltage - or Across-the-Line – Motor Starters are designed to connect motors directly to the full motor voltage.

These starters provide the maximum torque in those applications where inrush current restrictions do not prevent their use.

Since the current drawn from the power lines by a motor started across-the-line is typically 600% of normal full load amps (running current), the current demand could cause unacceptable line voltage dips and potential brownouts.

In addition to high starting currents, the motor produces a starting torque which is higher than full load torque; thus, motors started across-the-line must be capable of withstanding the impact of the starting torque.

Across-the-Line starters are widely used primarily on small HP motors and provide the lowest initial cost and the least maintenance requirements.

Magnetic Motor Starters do not provide motor disconnecting means nor protection against short circuit faults. Separate means have to be provided for these requirements, or a pump control panel may be ordered from other sections of this catalog.

Applied Motor Controls keeps a vast selection of enclosed across-the-line magnetic motor starters in stock for fast delivery and quick modifications.

Standard Features

- Fully welded heavy-duty steel enclosure with screwed-on door and padlocking hasp
- Type 3R rating suitable for use outdoors. Rain and sleet resistant
- Top and Bottom mounting holes
- Concentric Conduit Knock-Outs at bottom of enclosure for power and controls wiring conduits
- Gray powder-coating long-lasting finish suitable for use in harsh environments
- Full Voltage Magnetic Motor Starter with choice of coil voltage
- Solid State Class 10 Overload Relay with adjustable trip point and inherent protection against loss of phase
- Suitable for use with submersible motors
- UL 508 Listed Industrial Controls
- Grounding Lug

Hand-Off-Auto Switch Option

- Heavy Duty type 3R Selector Switch for selection of pump operating mode
- Fast-Acting Supplementary Fuses for protection of internal and external control circuit wiring against damage due to short circuits and ground faults
- Terminal Block for convenient field-wiring to and from a remote control device (ie: pressure switch)

Built Right and On-Time...Every Time!

Magnetic Motors Starters

Full Voltage

60 Hertz Motor		Starter Only		Starter with H-O-A Switch	
Motor Voltage	Maximum Horse Power	Part Number	List Price	Part Number	List Price
230V 1-PH	1...2	FMSC16L16S	\$ 340	FMSC16L16SH	\$ 490
	2...5	FMSC30L45S	\$ 440	FMSC30L45SH	\$ 590
	2...7-1/2	FMSC43L45S	\$ 540	FMSC43L45SH	\$ 690
	5...10	FMSC60L90S	\$ 640	FMSC60L90SH	\$ 790
	5...15	FMSC85L90S	\$ 740	FMSC85L90SH	\$ 890

1. Unless otherwise specified, Starter Coil Voltage is same as line voltage
2. Call factory for HP and Voltages not shown
3. See Pages 17 & 18 for Options
4. For Start/Stop Pushbutton in lieu of the H-O-A Switch, Substitute suffix "H" with "S"

Magnetic Motors Starters

Full Voltage

60 Hertz Motor		Starter Only		Starter with H-O-A Switch	
Motor Voltage	Horse Power RANGE	Part Number	List Price	Part Number	List Price
200V 3-PH	1...3	FMSC16L16	\$ 340	FMSC16L16H	\$ 490
	3...7-1/2	FMSC30L45	\$ 440	FMSC30L45H	\$ 590
	3...10	FMSC43L45	\$ 540	FMSC43L45H	\$ 690
	7-1/2...15	FMSC60L90	\$ 640	FMSC60L90H	\$ 790
	7-1/2...20	FMSC85L90	\$ 740	FMSC85L90H	\$ 890

1. Unless otherwise specified, Starter Coil Voltage is same as line voltage
2. Call factory for HP and Voltages not shown
3. See Pages 17 & 18 for Options
4. For Start/Stop Pushbutton in lieu of the H-O-A Switch, Substitute suffix "H" with "S"

Magnetic Motors Starters

Full Voltage

60 Hertz Motor		Starter Only		Starter with H-O-A Switch	
Motor Voltage	Horse Power RANGE	Part Number	List Price	Part Number	List Price
230V 3-PH	1...3	FMSC16L16	\$ 340	FMSC16L16H	\$ 490
	3...7-1/2	FMSC30L45	\$ 440	FMSC30L45H	\$ 590
	3...10	FMSC43L45	\$ 540	FMSC43L45H	\$ 690
	7-1/2...20	FMSC60L90	\$ 640	FMSC60L90H	\$ 790
	7-1/2...25	FMSC85L90	\$ 740	FMSC85L90H	\$ 890
460V 3-PH	2...7-1/2	FMSC16B16	\$ 340	FMSC16B16H	\$ 490
	7-1/2...15	FMSC30B45	\$ 440	FMSC30B45H	\$ 590
	7-1/2...25	FMSC43B45	\$ 540	FMSC43B45H	\$ 690
	15...40	FMSC60B90	\$ 640	FMSC60B90H	\$ 790
	15...50	FMSC85B90	\$ 740	FMSC85B90H	\$ 890

1. Starter Coil Voltage is same as line voltage
2. Call factory for HP and Voltages not shown
3. See Pages 17 & 18 for Options
4. For Start/Stop Pushbutton in lieu of the H-O-A Switch, Substitute suffix "H" with "S"

Product Description

An Across-the-Line pump control panel is a "combination starter" which combines a full voltage magnetic starter along with a fusible switch or a circuit breaker.

Our pump panels offer the following protection:

- Protection against short circuit faults
- Means of disconnecting the motors from the supply lines
- Overload protection

Across-the-Line - or Full Voltage - starters are designed to connect motors directly to the full motor voltage and provide the maximum torque in those applications where inrush current restrictions do not prevent their use.

Since the current drawn from the power lines by a motor started across-the-line is typically 600% of normal full load amps (running current), power companies are increasingly limiting the use of full voltage starters to specific HP ranges.

In addition to high starting currents, the motor produces a starting torque which is higher than full load torque; thus, motors started across-the-line must be capable of withstanding the impact of the starting torque.

Across-the-Line starters provide the lowest initial cost and the lowest maintenance requirements.

Applied Motor Controls keeps a vast selection of across-the-line pump control panels in stock for fast delivery and quick modifications to meet your most demanding needs.

Standard Features

- Type 3R enclosure for use outdoors. Rain and sleet resistant. Fully welded steel construction with hinged door and provisions for padlocking
- Gray powder-coating finish suitable for use in harsh environments
- Choice of disconnect style: Fusible Switch, or Circuit Breaker
- Fusible Disconnect Switches include factory-installed J-Class time-delay dual-element current-limiting power fuses
- Through the door disconnect operator with provisions for padlocking in the off position
- Full Voltage Magnetic Motor Starter with choice of coil voltage
- Solid State Class 10 Overload Relay with adjustable trip point and inherent protection against loss of phase
- Suitable for use with submersible motors
- Fast-Acting Supplementary Fuses for protection of internal and external control circuit wiring against damage due to short circuits and ground faults
- Hand-Off-Auto Selector Switch
- Terminal Block for ease of wiring to and from a remote control device
- UL 508 Listed Industrial Controls
- Suitable for use as Service Equipment

Built Right and On-Time...Every Time!

Pump Control Panels

Across-the-Line

1 Phase Motor		Fusible Type		Breaker Type	
Motor Voltage	Maximum Horse Power	Part Number	List Price	Part Number	List Price
230V 60HZ	1	P1231FVFR	\$ 1,020	P1231FVCR	\$ 1,360
	1 – 1/2	P1.5231FVFR	\$ 1,020	P1.5231FVCR	\$ 1,360
	2	P2231FVFR	\$ 1,020	P2231FVCR	\$ 1,360
	3	P3231FVFR	\$ 1,160	P3231FVCR	\$ 1,510
	5	P5231FVFR	\$ 1,250	P5231FVCR	\$ 1,520
	7 – 1/2	P7231FVFR	\$ 1,420	P7231FVCR	\$ 1,710
	10	P10231FVFR	\$ 1,780	P10231FVCR	\$ 2,000
	15	P15231FVFR	\$ 2,360	P15231FVCR	\$ 3,200

1. Fusible Type Panels include J-Class Power Fuses
2. Unless otherwise specified, Starter Coil Voltage is same as line voltage
3. Call factory for HP and Voltages not shown
4. See Pages 17 & 18 for Factory-Installed Modifications

Pump Control Panels

Across-the-Line

3 Phase Motor		Fusible Type		Breaker Type	
Motor Voltage	Maximum Horse Power	Part Number	List Price	Part Number	List Price
200V 60HZ	3	P3203FVFR	\$ 1,020	P3203FVCR	\$ 1,360
	5	P5203FVFR	\$ 1,160	P5203FVCR	\$ 1,510
	7 – 1/2	P7203FVFR	\$ 1,250	P7203FVCR	\$ 1,520
	10	P10203FVFR	\$ 1,420	P10203FVCR	\$ 1,710
	15	P15203FVFR	\$ 1,780	P15203FVCR	\$ 2,000
	20	P20203FVFR	\$ 1,840	P20203FVCR	\$ 2,200
	25	P25203FVFR	\$ 2,360	P25203FVCR	\$ 3,200
	30	P30203FVFR	\$ 3,060	P30203FVCR	\$ 3,430
	40	P40203FVFR	\$ 4,020	P40203FVCR	\$ 4,160
	50	P50203FVFR	\$ 7,110	P50203FVCR	\$ 8,530

1. Fusible Type Panels include J-Class Power Fuses
2. Unless otherwise specified, Starter Coil Voltage is same as line voltage
3. Call factory for HP and Voltages not shown
4. See Pages 17 & 18 for Options

Pump Control Panels

Across-the-Line

3 Phase Motor		Fusible Type		Breaker Type	
Motor Voltage	Maximum Horse Power	Part Number	List Price	Part Number	List Price
230V 60HZ	3	P3233FVFR	\$ 1,020	P3233FVCR	\$ 1,360
	5	P5233FVFR	\$ 1,020	P5233FVCR	\$ 1,360
	7 – 1/2	P7233FVFR	\$ 1,160	P7233FVCR	\$ 1,510
	10	P10233FVFR	\$ 1,250	P10233FVCR	\$ 1,520
	15	P15233FVFR	\$ 1,420	P15233FVCR	\$ 1,710
	20	P20233FVFR	\$ 1,780	P20233FVCR	\$ 2,000
	25	P25233FVFR	\$ 1,840	P25233FVCR	\$ 2,200
	30	P30233FVFR	\$ 2,360	P30233FVCR	\$ 3,200
	40	P40233FVFR	\$ 3,060	P40233FVCR	\$ 3,430
	50	P50233FVFR	\$ 4,020	P50233FVCR	\$ 4,160
	60	P60233FVFR	\$ 7,110	P60233FVCR	\$ 8,530
	460V 60HZ	3	P3463FVFR	\$ 1,020	P3463FVCR
5		P5463FVFR	\$ 1,020	P5463FVCR	\$ 1,360
7 – 1/2		P7463FVFR	\$ 1,020	P7463FVCR	\$ 1,360
10		P10463FVFR	\$ 1,030	P10463FVCR	\$ 1,370
15		P15463FVFR	\$ 1,160	P15463FVCR	\$ 1,500
20		P20463FVFR	\$ 1,250	P20463FVCR	\$ 1,520
25		P25463FVFR	\$ 1,360	P25463FVCR	\$ 1,530
30		P30463FVFR	\$ 1,420	P30463FVCR	\$ 1,710
40		P40463FVFR	\$ 1,780	P40463FVCR	\$ 2,000
50		P50463FVFR	\$ 1,840	P50463FVCR	\$ 2,200
60		P60463FVFR	\$ 2,360	P60463FVCR	\$ 3,200
75		P75463FVFR	\$ 3,060	P75463FVCR	\$ 3,430
100		P100463FVFR	\$ 4,020	P100463FVCR	\$ 4,160
125		P125463FVFR	\$ 7,110	P125463FVCR	\$ 8,530
150		P150463FVFR	\$ 7,110	P150463FVCR	\$ 8,530
200		P200463FVFR		P200463FVCR	

1. Fusible Type Panels include J-Class Power Fuses
2. Unless otherwise specified, Starter Coil Voltage is same as line voltage
3. Call factory for HP and Voltages not shown
4. See Pages 17 & 18 for Options

Product Description

A Part-Winding pump control panel is a “combination starter” which combines a part-winding magnetic starter along with a fusible switch or a circuit breaker.

Our pump panels offer the following protection:

- Protection against short circuit faults
- Means of disconnecting the motors from the supply lines
- Overload protection

Part-Winding motor starters (or two-step starters) provide economical reduced current starting in applications where the supplied power restricts the increments of current drawn from the lines, and a simple method of accelerating loads with low starting torque.

These starters can be used with most standard dual-voltage motors on the lower voltage, and with special Part-Winding motors designed for use with any single voltage.

Part-Winding starters are designed to connect one winding of the motor to the line drawing approximately 65% of normal locked rotor amps and developing about 45% of normal motor torque. After a pre-set time interval, the second winding is connected to the line in parallel with the first allowing the motor to develop its rated torque.

Applied Motor Controls offers fast delivery of standard and custom part-winding pump control panels to meet your most demanding needs.

Standard Features

- Fully welded heavy-duty steel enclosure with gasketed hinged door and provisions for padlocking. Gray powder-coating finish suitable for use in harsh environments
- Type 3R rating suitable for use outdoors. Rain and sleet resistant. Top and bottom brackets for wall or pole mounting
- Choice of disconnect style: Fusible Switch, or Circuit Breaker
- Fusible Disconnect Switches include factory-installed J-Class time-delay dual-element current-limiting power fuses
- Through the door disconnect operator with provisions for padlocking in the off position
- Part-Winding Magnetic Motor Starter with choice of coil voltage
- (2) Solid State Class 10 Overload Relays with adjustable trip point and inherent protection against loss of phase
- Fast-Acting Supplementary Fuses for protection of internal and external control circuit wiring against damage due to short circuits and ground faults
- Hand-Off-Auto Selector Switch
- Terminal Block for ease of wiring to and from a remote control device
- UL 508 Listed Industrial Controls
- Suitable for use as Service Equipment

Built Right and On-Time...Every Time!

Pump Control Panels

Part-Winding

3 Phase Motor		Fusible Type		Breaker Type	
Motor Voltage	Maximum Horse Power	Part Number	List Price	Part Number	List Price
230V 60HZ	10	P10233PWFR	\$ 2,300	P10233PWCR	Call Factory
	15	P15233PWFR	\$ 2,610	P15233PWCR	Call Factory
	20	P20233PWFR	\$ 3,300	P20233PWCR	Call Factory
	25	P25233PWFR	\$ 3,440	P25233PWCR	Call Factory
	30	P30233PWFR	\$ 3,440	P30233PWCR	Call Factory
	40	P40233PWFR	\$ 4,410	P40233PWCR	Call Factory
	50	P50233PWFR	\$ 4,490	P50233PWCR	Call Factory
	60	P60233PWFR	\$ 5,770	P60233PWCR	Call Factory
	75	P75233PWFR	\$ 10,750	P75233PWCR	Call Factory
	100	P100233PWFR	\$ 10,750	P100233PWCR	Call Factory
460V 60HZ	15	P15463PWFR	\$ 2,300	P15463PWCR	Call Factory
	20	P20463PWFR	\$ 2,300	P20463PWCR	Call Factory
	25	P25463PWFR	\$ 2,610	P25463PWCR	Call Factory
	30	P30463PWFR	\$ 2,610	P30463PWCR	Call Factory
	40	P40463PWFR	\$ 3,300	P40463PWCR	Call Factory
	50	P50463PWFR	\$ 3,300	P50463PWCR	Call Factory
	60	P60463PWFR	\$ 3,440	P60463PWCR	Call Factory
	75	P75463PWFR	\$ 4,410	P75463PWCR	Call Factory
	100	P100463PWFR	\$ 4,490	P100463PWCR	Call Factory
	125	P125463PWFR	\$ 9,900	P125463PWCR	Call Factory
	150	P150463PWFR	\$ 9,900	P150463PWCR	Call Factory
	200	P200463PWFR	\$ 10,750	P200463PWCR	Call Factory
	250	P250463PWFR	\$ 12,420	P250463PWCR	Call Factory

1. Fusible Type Panels include J-Class Power Fuses
2. Unless otherwise specified, Starter Coil Voltage is same as line voltage
3. Call factory for HP and Voltages not shown
4. See Pages 17 & 18 for Options

Product Description

A Reduced Voltage Auto-transformer Start pump control panel is a “combination starter” which combines an auto-transformer starter along with a fusible switch or a circuit breaker.

Our pump panels offer the following protection:

- Protection against short circuit faults
- Means of disconnecting the motors from the supply lines
- Overload protection

Reduced Voltage Auto-Transformer motor starters are widely used in applications where the supplied power restricts the increments of current drawn from the supply lines.

These starters deliver the highest starting torque per ampere of line current , thus providing reduced inrush current with minimum sacrifice of starting torque.

Three auto-transformer taps offer the flexibility to change the starting current and torque characteristics to meet the requirements of most applications.

Closed Transition provides uninterrupted power connection to the motor in the transition from reduced voltage to full voltage mode. This design prevents a second current inrush and provides smoother acceleration of the motor than open-transition starters.

Applied Motor Controls offers fast delivery of standard and custom auto-transformer pump control panels to meet your most demanding needs.

Standard Features

- Fully welded heavy-duty steel enclosure with gasketed hinged door and provisions for padlocking. Gray powder-coating finish suitable for use in harsh environments
- Type 3R rating suitable for use outdoors. Rain and sleet resistant.
- Choice of disconnect style: Fusible Switch, or Circuit Breaker
- Fusible Disconnect Switches include factory-installed J-Class current-limiting time-delay dual-element power fuses
- Through the door disconnect operator with provisions for padlocking in the off position
- Reduced Voltage Auto-transformer Closed-Transition Motor Starter with choice of coil voltage and Motor Starting Auto-transformer
- Solid State Class 10 Overload Relay with adjustable trip point and inherent protection against loss of phase
- Fast-Acting Supplementary Fuses for protection of internal and external control circuit wiring against damage due to short circuits and ground faults
- Hand-Off-Auto Selector Switch
- Terminal Block for ease of wiring to and from a remote control device
- UL 508 Listed Industrial Controls
- Suitable for use as Service Equipment

Built Right and On-Time...Every Time!

Pump Control Panels

Auto-Transformer

3 Phase Motor		Fusible Type		Breaker Type	
Motor Voltage	Maximum Horse Power	Part Number	List Price	Part Number	List Price
230V 60HZ	10	P10233ATFR	Call Factory	P10233ATCR	Call Factory
	15	P15233ATFR	Call Factory	P15233ATCR	Call Factory
	20	P20233ATFR	Call Factory	P20233ATCR	Call Factory
	25	P25233ATFR	Call Factory	P25233ATCR	Call Factory
	30	P30233ATFR	Call Factory	P30233ATCR	Call Factory
	40	P40233ATFR	Call Factory	P40233ATCR	Call Factory
	50	P50233ATFR	Call Factory	P50233ATCR	Call Factory
	60	P60233ATFR	Call Factory	P60233ATCR	Call Factory
	75	P75233ATFR	Call Factory	P75233ATCR	Call Factory
	100	P100233ATFR	Call Factory	P100233ATCR	Call Factory
460V 60HZ	15	P15463ATFR	Call Factory	P15463ATCR	Call Factory
	20	P20463ATFR	Call Factory	P20463ATCR	Call Factory
	25	P25463ATFR	Call Factory	P25463ATCR	Call Factory
	30	P30463ATFR	Call Factory	P30463ATCR	Call Factory
	40	P40463ATFR	Call Factory	P40463ATCR	Call Factory
	50	P50463ATFR	Call Factory	P50463ATCR	Call Factory
	60	P60463ATFR	Call Factory	P60463ATCR	Call Factory
	75	P75463ATFR	Call Factory	P75463ATCR	Call Factory
	100	P100463ATFR	Call Factory	P100463ATCR	Call Factory
	125	P125463ATFR	Call Factory	P125463ATCR	Call Factory
	150	P150463ATFR	Call Factory	P150463ATCR	Call Factory
	200	P200463ATFR	Call Factory	P200463ATCR	Call Factory

1. Fusible Type Panels include J-Class Power Fuses
2. Unless otherwise specified, Starter Coil Voltage is same as line voltage
3. Call factory for HP and Voltages not shown
4. See Pages 17 & 18 for Options

Product Description

A Reduced Voltage Solid State Starter pump control panel is a “combination starter” which combines a Digital Solid State Soft Starter along with a fusible switch or a circuit breaker.

Our pump panels offer the following protection:

- Protection against short circuit faults
- Means of disconnecting the motors from the supply lines
- Overload protection

Reduced Voltage Solid State motor starters are widely used in applications where reduced voltage starting is desired, or where the supplied power restricts the increments of current drawn from the supply lines.

A microprocessor controlled solid state motor controller provides a wide range of adjustable starting parameters, and optional stopping parameters, which make these starters suitable for use in a wide range of applications.

Soft Starters provide a closed loop current ramp for smooth step-less motor acceleration, help reduce downtime, extend motor life, and protect the driven machinery against destructive shock.

In addition, Applied Motor Controls’ standard design features a by-pass contactor to control the motor after it reaches full speed.

Applied Motor Controls offers fast delivery of standard and custom soft start pump control panels to meet your most demanding needs.

Standard Features

- Fully welded heavy-duty steel enclosure with gasketed hinged door and provisions for padlocking
- Type 3R rating suitable for use outdoors. Rain and sleet resistant
- Gray powder-coating finish suitable for use in harsh environments
- Choice of disconnect style: Fusible Switch, or Circuit Breaker
- Fusible Disconnect Switches include factory-installed J-Class time-delay dual-element current-limiting power fuses
- Through the door disconnect operator with provisions for padlocking in the off position
- Digital Solid State Soft Starter with Bypass Contactor
- Solid State Overload protection
- 120V Control Circuit Transformer with primary and secondary protective fuses
- Hand-Off-Auto Selector Switch
- Terminal Block for ease of wiring to and from a remote control device
- UL 508 Listed Industrial Controls
- Suitable for use as Service Equipment

Built Right and On-Time...Every Time!

Pump Control Panels

Solid State Soft Start

3 Phase Motor		Fusible Type		Breaker Type	
Motor Voltage	Maximum Horse Power	Part Number	List Price	Part Number	List Price
200V 60HZ	10	P10203SSFR	\$ 4,190	P10203SSCR	\$ 4,610
	15	P15203SSFR	\$ 5,470	P15203SSCR	\$ 5,810
	20	P20203SSFR	\$ 5,470	P20203SSCR	\$ 5,810
	25	P25203SSFR	\$ 8,400	P25203SSCR	\$ 9,230
	30	P30203SSFR	\$ 11,400	P30203SSCR	\$ 11,850
	40	P40203SSFR	\$ 12,800	P40203SSCR	\$ 13,200
	50	P50203SSFR	\$ 14,800	P50203SSCR	\$ 16,280
230V 60HZ	10	P10233SSFR	\$ 4,190	P10233SSCR	\$ 4,610
	15	P15233SSFR	\$ 5,470	P15233SSCR	\$ 5,810
	20	P20233SSFR	\$ 5,470	P20233SSCR	\$ 5,810
	25	P25233SSFR	\$ 5,470	P25233SSCR	\$ 5,810
	30	P30233SSFR	\$ 8,400	P30233SSCR	\$ 9,230
	40	P40233SSFR	\$ 11,400	P40233SSCR	\$ 11,850
	50	P50233SSFR	\$ 12,800	P50233SSCR	\$ 13,200
	60	P60233SSFR	\$ 14,800	P60233SSCR	\$ 16,280
460V 60HZ	15	P15463SSFR	\$ 2,750	P15463SSCR	\$ 3,030
	20	P20463SSFR	\$ 4,190	P20463SSCR	\$ 4,610
	25	P25463SSFR	\$ 4,190	P25463SSCR	\$ 4,610
	30	P30463SSFR	\$ 5,470	P30463SSCR	\$ 5,810
	40	P40463SSFR	\$ 5,470	P40463SSCR	\$ 5,810
	50	P50463SSFR	\$ 5,470	P50463SSCR	\$ 5,810
	60	P60463SSFR	\$ 8,400	P60463SSCR	\$ 9,230
	75	P75463SSFR	\$ 11,400	P75463SSCR	\$ 11,850
	100	P100463SSFR	\$ 12,800	P100463SSCR	\$ 13,200
	125	P125463SSFR	\$ 14,800	P125463SSCR	\$ 16,280
	150	P150463SSFR	\$ 14,800	P150463SSCR	\$ 16,280
	200	P200463SSFR	\$ 17,500	P200463SSCR	\$ 17,500

1. Fusible Type Panels include J-Class Power Fuses
2. Unless otherwise specified, Starter Coil Voltage is same as line voltage
3. Call factory for HP and Voltages not shown
4. See Pages 17 & 18 for Options

Product Description

A Wye-Delta pump control panel is a “combination starter” which combines a wye-delta motor starter along with a fusible switch or a circuit breaker.

Our pump panels offer the following protection:

- Protection against short circuit faults
- Means of disconnecting the motors from the supply lines
- Overload protection

Wye-Delta Open-Transition motor starters (or Star Delta starters) provide economical reduced current starting in applications where the supplied power restricts the increments of current drawn from the lines.

These starters are designed for use in those applications involving long acceleration time or frequent starts.

This starting method is typically used to start motors driving high inertia loads, in applications requiring low starting torque, and in cases where low starting torque is permissible.

Wye-Delta starting requires a six or twelve lead Delta-Connected motor. The motor is started in the Wye configuration receiving about 58% of the full line voltage and developing 33% of the full voltage torque. When the motor has accelerated, it is re-connected to the line with the windings connected for normal Delta operation.

Applied Motor Controls offers fast delivery of standard and custom Wye-Delta pump control panels to meet your most demanding needs.

Standard Features

- Fully welded heavy-duty steel enclosure with gasketed hinged door and provisions for padlocking. Gray powder-coating finish suitable for use in harsh environments
- Type 3R rating suitable for use outdoors. Rain and sleet resistant.
- Choice of disconnect style: Fusible Switch, or Circuit Breaker
- Fusible Disconnect Switches include factory-installed J-Class time-delay dual-element current-limiting power fuses
- Through the door disconnect operator with provisions for padlocking in the off position
- Wye-Delta Open-Transition Magnetic Motor Starter with choice of coil voltage
- Solid State Class 10 Overload Relay with adjustable trip point and inherent protection against loss of phase
- Fast-Acting Supplementary Fuses for protection of internal and external control circuit wiring against damage due to short circuits and ground faults
- Hand-Off-Auto Selector Switch
- Terminal Block for ease of wiring to and from a remote control device
- UL 508 Listed Industrial Controls
- Suitable for use as Service Equipment

Built Right and On-Time...Every Time!

Pump Control Panels

Wye-Delta

3 Phase Motor		Fusible Type		Breaker Type	
Motor Voltage	Maximum Horse Power	Part Number	List Price	Part Number	List Price
230V 60HZ	10	P10233YDFR	\$ 2,800	P10233YDCR	\$ 3,130
	15	P15233YDFR	\$ 3,200	P15233YDCR	\$ 3,600
	20	P20233YDFR	\$ 3,910	P20233YDCR	\$ 4,330
	25	P25233YDFR	\$ 4,090	P25233YDCR	\$ 5,110
	30	P30233YDFR	\$ 4,090	P30233YDCR	\$ 5,110
	40	P40233YDFR	\$ 5,100	P40233YDCR	\$ 5,550
	50	P50233YDFR	\$ 5,210	P50233YDCR	\$ 5,660
	60	P60233YDFR	\$ 6,860	P60233YDCR	\$ 8,430
	75	P75233YDFR	\$ 12,540	P75233YDCR	\$ 12,790
	100	P100233YDFR	\$ 12,540	P100233YDCR	\$ 12,790
460V 60HZ	15	P15463YDFR	\$ 2,800	P15463YDCR	\$ 3,130
	20	P20463YDFR	\$ 2,800	P20463YDCR	\$ 3,130
	25	P25463YDFR	\$ 2,800	P25463YDCR	\$ 3,130
	30	P30463YDFR	\$ 3,200	P30463YDCR	\$ 3,600
	40	P40463YDFR	\$ 3,910	P40463YDCR	\$ 4,330
	50	P50463YDFR	\$ 4,090	P50463YDCR	\$ 5,110
	60	P60463YDFR	\$ 4,090	P60463YDCR	\$ 5,110
	75	P75463YDFR	\$ 5,100	P75463YDCR	\$ 5,550
	100	P100463YDFR	\$ 5,210	P100463YDCR	\$ 5,660
	125	P125463YDFR	\$ 6,860	P125463YDCR	\$ 8,430
	150	P150463YDFR	\$ 12,540	P150463YDCR	\$ 12,790
	200	P200463YDFR	\$ 12,540	P200463YDCR	\$ 12,790

1. Fusible Type Panels include J-Class Power Fuses
2. Unless otherwise specified, Starter Coil Voltage is same as line voltage
3. Call factory for HP and Voltages not shown
4. See Pages 17 & 18 for Options

Factory-Installed Modifications

Description	Option Code	List Price
Control Circuit Transformer With Primary & Secondary Protective Fuses		
208/240/480 – 120V @ 50VA	CT50	\$ 350
208/240/480 – 120V @ 100VA	CT100	\$ 370
208/240/480 – 120V @ 150VA	CT150	\$ 400
208/240/480 – 120V @ 250VA	CT250	\$ 460
208/240/480 – 120V @ 500VA	CT500	\$ 610
Interposing Relay For separate control voltage input (** Specify required Voltage when ordering)	IR-**	\$ 230
Time Delay Relay (** Specify required function when Ordering) Note: This option requires a control circuit transformer	TD-**	\$ 450
Programmable Time Clock 24 Hour, 7 Day function Note: This option requires a control circuit transformer	TC	\$ 450
Liquid Level Relay (** Specify required function when ordering) Note: This option requires a control circuit transformer	LLR-**	\$ 700
Indicating Light Specify Function and Lens color when ordering (ie: run/red)	PL-**	\$ 200
Electronic Programmable Overload Relay Protects 3 Phase Motors against: Overload, Underload, High Voltage, Low Voltage, Loss of Phase, Phase Reversal, Phase & Voltage, Unbalance, Rapid Cycling, and Ground Fault		
Motor Full Load Amps: 2 – 90 Amps	DEOL	\$ 1,560
Motor Full Load Amps: 91 – 600 Amps (includes current transformers)	CTEOL	\$ 2,190

Factory-Installed Modifications

Description	Option Code	List Price
Phase & Voltage Monitor Protects Three Phase motors against: High Voltage, Low Voltage, Phase Reversal, Loss of Phase, and Unbalance	PMR	\$ 650
Secondary Surge Arrester Offers a degree of protection against damage due to lightning strikes	LA	\$ 460
Surge Capacitor Controls surges which are too light or fast for a surge arrester	SC	\$ 460
Low Suction Cut-Off Option includes a Terminal Block for remote pressure switch, a Red Indicating Light, and a Timing Relay to prevent nuisance tripping Note: This option requires a Control Circuit Transformer	LSC	\$ 750
High Pressure Shutdown Option includes a Terminal Block for remote pressure switch, a Red Indicating Light, and manual Reset Pushbutton Note: This option requires a Control Circuit Transformer	HPS	\$ 650
Elapsed Hour Meter Records motor running time in Hours, Non Reset, 99999.9 Hours Note: This option requires a control circuit transformer	ETM	\$ 320
NEMA Type 4 Steel Enclosure Water & Dust-Tight, Outdoors	N4	Call for Prices
NEMA Type 4X Stainless Steel Enclosure Water & Dust-Tight, Outdoors, Corrosion-Resistant	N4XS	Call for Prices
NEMA Type 4X Fiberglass-Reinforced Polyester Enclosure Water & Dust-Tight, Outdoors, Corrosion-Resistant	N4XF	Call for Prices
Starter Auxiliary Contacts 1 N/O & 1N/C contacts interlocked with starter Specify if contacts are to be "dry" or "powered"	AUX	\$ 250

Duplex Booster Pump Control Panels

Product Description

Duplex Pump Controls Panels are designed to operate and control two booster pump motors on single system.

These panels are widely used in those applications where maintaining a specific system pressure is required.

Applied Motor Controls' standard duplex pump panel is designed to provide both "alternating" and "duplexing" modes.

Alternating mode: This function provides for relatively equal wear of the two pump motors, typically of the same HP rating, driven by the controller by reversing the "Lead" and "Lag" roles of the motors on each successive cycle. Automatic alternation is accomplished when one or both motors come to a stop.

Duplexing mode: This mode provides stand-by capacity for use of a second pump motor when the system demand exceeds the normal requirements of a single motor, or when one of the motors fail.

Applied Motor Controls offers a wide range of UL Listed factory-installed options which can enhance the control and protection of the pumps.

Typical options include:

- Main Disconnect Switch
- Jockey Pump Starter
- Minimum Run Timer
- Low System Pressure alarm
- Low Suction cut-off
- High System Pressure shutdown
- Elapsed Hour Meters
- Pilot Lights
- Pressure Switches, etc.

Standard Features

- Fully welded heavy-duty steel enclosure with gasketed hinged door and provisions for padlocking
- Type 3R rating suitable for use outdoors. Rain and sleet resistant
- Gray powder-coating finish suitable for use in harsh environments
- Power Terminal Block for termination of line supply cables
- Choice of two disconnects: Fusible Switches with J-Class Factory-installed power fuses, or Thermal-Magnetic Molded Case Circuit Breakers
- (2) Through the door disconnect operators with provisions for padlocking in the off position
- (2) Full Voltage Magnetic Motor Starters with 120VAC coil voltage
- (2) Solid State Class 10 Overload Relays with adjustable trip point and inherent protection against loss of phase
- Solid State Duplex Alternator with Alternating and Duplexing functions
- 120V Control Circuit Transformer with primary and secondary protective fuses
- (2) Hand-Off-Auto Selector Switches
- (2) Terminal Blocks for two remote pressure switches
- UL 508 Listed Industrial Controls

Built Right and On-Time...Every Time!

Duplex Booster Pump Control Panels

3 Phase Motor		Fusible Type		Breaker Type	
Motor Voltage	Maximum Horse Power	Part Number	List Price	Part Number	List Price
200V 60HZ	3	DP3203FVFR	\$ 3,120	DP3203FVCR	\$ 3,810
	5	DP5203FVFR	\$ 3,140	DP5203FVCR	\$ 3,830
	7 – 1/2	DP7203FVFR	\$ 3,480	DP7203FVCR	\$ 4,170
	10	DP10203FVFR	\$ 3,660	DP10203FVCR	\$ 4,200
	15	DP15203FVFR	\$ 3,810	DP15203FVCR	\$ 4,490
	20	DP20203FVFR	\$ 5,020	DP20203FVCR	\$ 5,840
	25	DP25203FVFR	\$ 5,040	DP25203FVCR	\$ 6,760
230V 60HZ	3	DP3233FVFR	\$ 3,120	DP3233FVCR	\$ 3,810
	5	DP5233FVFR	\$ 3,140	DP5233FVCR	\$ 3,830
	7 – 1/2	DP7233FVFR	\$ 3,480	DP7233FVCR	\$ 4,170
	10	DP10233FVFR	\$ 3,660	DP10233FVCR	\$ 4,200
	15	DP15233FVFR	\$ 3,810	DP15233FVCR	\$ 4,490
	20	DP20233FVFR	\$ 4,880	DP20233FVCR	\$ 5,560
	25	DP25233FVFR	\$ 4,950	DP25233FVCR	\$ 6,610
	30	DP30233FVFR	\$ 6,140	DP30233FVCR	\$ 7,800
460V 60HZ	3	DP3463FVFR	\$ 3,120	DP3463FVCR	\$ 3,810
	5	DP5463FVFR	\$ 3,120	DP5463FVCR	\$ 3,810
	7 – 1/2	DP7463FVFR	\$ 3,120	DP7463FVCR	\$ 3,810
	10	DP10463FVFR	\$ 3,140	DP10463FVCR	\$ 3,830
	15	DP15463FVFR	\$ 3,480	DP15463FVCR	\$ 4,170
	20	DP20463FVFR	\$ 3,660	DP20463FVCR	\$ 4,200
	25	DP25463FVFR	\$ 3,810	DP25463FVCR	\$ 4,490
	30	DP30463FVFR	\$ 3,810	DP30463FVCR	\$ 4,490
	40	DP40463FVFR	\$ 4,880	DP40463FVCR	\$ 5,560
	50	DP50463FVFR	\$ 4,950	DP50463FVCR	\$ 6,610
	60	DP60463FVFR	\$ 6,140	DP60463FVCR	\$ 7,800

1. Fusible Type Panels include J-Class Power Fuses
2. Unless otherwise specified, Starters Coil Voltage 120VAC
3. Call factory for HP and Voltages not shown
4. See Pages 21 & 22 for Options

Duplex Booster Pump Panels

Options

Description	Option Code	List Price
Low Suction Cut-Off Option includes a terminal block for remote pressure switch, a Red Indicating Light, and a Timing Relay	LSC	\$ 750
Low Pressure Alarm Option includes a terminal block for remote pressure switch, a Red Indicating Light, and a Timing Relay	LSP	\$ 750
High Pressure Shutdown Option includes a terminal block for remote pressure switch, a Red Indicating Light, and manual Reset Pushbutton	HPS	\$ 650
Interposing Relay For use with separate control voltage (** Indicate required Voltage when ordering)	IR-**	\$ 230
Time Delay Relay (** Indicate required function when Ordering)	TD-**	\$ 450
Programmable Time Clock 24 Hour, 7 Day function	TC	\$ 450
Elapsed Hour Meter 99999.9 Hours, Non Reset Quantity Two	ETM	\$ 640
Cycle Counter 6 Digits, Non Reset Quantity Two	CC	\$ 660
Indicating Light (** Indicate Lens color and Function when ordering)	PL-**	\$ 200

Duplex Booster Pump Panels

Options

Description	Option Code	List Price
Phase & Voltage Monitor Protects 3-Phase motors against: High Voltage, Low Voltage, Phase Reversal, Loss of Phase, and Unbalance	PMR	\$ 650
Surge/Lightning Arrester	LA	\$ 460
Surge Capacitor	SC	\$ 460
Starter Auxiliary Contacts Option includes 1-N.O. & 1-N.C. Auxiliary Dry or Powered Contacts for interfacing with remote loads or monitoring Quantity Two Sets (one per starter)	AUX	\$ 500
Electronic Programmable Overload Relay, Motor Saver 777 Protects 3-Phase Motors against: Overload, Underload, High Voltage, Low Voltage, Loss of Phase, Phase Reversal, Phase & Voltage Unbalance, Rapid Cycling, and Ground Fault Quantity Two <p style="text-align: center;"><u>Motor Full Load Amps:</u></p> <p style="text-align: center;">2 – 90 Amps</p>	DEOL	\$ 3,120
External Electric Reset Pushbutton for Motor Saver 777 Quantity Two	EOLR	\$ 580
Deduct for Auto Duplex Alternator	NALT	- \$ 300
Terminal Block 3P, 600V, 30 AMPS (Specify Function)	TB	\$ 50

Simplex Lift Station Pump Panels

Product Description

Simplex Lift Station Pump Control Panels are designed to control the level in a municipal or industrial de-watering Lift Station housing a single pump.

When the level rises to a predetermined level, as sensed by an external level sensor (ie: float switch), the pump is turned on. As the level recedes to a predetermined level, as sensed by a level sensor, the pump is turned off.

A "Simplex" panel consist of a single across-the-line combination motor starter which provides protection against short circuit faults, motor overload faults, motor disconnecting means, and means to automatically turning the pump motor on/off.

Typical applications include sewage lift stations, storm drain lift station, or any installation where de-watering is required.

Applied Motor Controls' Simplex Lift Station Pump Panels can be designed to incorporate a wide selection of power, monitoring and control options meant to enhance the protection or performance of the pump, or to meet the most demanding job specifications.

Standard Features

- UL 508 Listed Industrial Control serialized label
- UL type 3R Outdoor Steel Enclosure Fully gasketed hinged door with provision for padlocks
- Top and bottom brackets for wall or pole mounting
- Gray powder-coating finish suitable for use in harsh environments
- Molded Case Circuit Breaker with Thermal-Magnetic Trip (Optional Fusible Switch with Fuses available)
- External Handle mechanism interlocked to door for Circuit Breaker. Handle features provisions for up to 3 padlocks when in the "off", and prevents door opening when in the "on" position
- Full Voltage Magnetic Motor Starter with 120VAC coil
- Solid State Overload Relay with adjustable trip point and inherent protection against loss of phase
- 120V Control Circuit Transformer with primary & secondary protective fuses
- Hand-Off-Auto Selector Switch
- Terminal Blocks for two remote Float Switches: Pump Off, Pump On
- Grounding Lug

Built Right and On-Time...Every Time!

Simplex Lift Station Pump Panels

3 Phase Motor			
Motor Voltage	Maximum Horse Power	Part Number	List Price
230V 60HZ	1	SPX1233C	\$ 2,070
	1 – 1/2	SPX1.5233C	\$ 2,070
	2	SPX2233C	\$ 2,070
	3	SPX3233C	\$ 2,090
	5	SPX5233C	\$ 2,100
	7-1/2	SPX7233C	\$ 2,200
	10	SPX10233C	\$ 2,240
	15	SPX15233C	\$ 2,560
	20	SPX20233C	\$ 2,660
	25	SPX25233C	\$ 2,720
	460V 60HZ	1	SPX1463C
1 – 1/2		SPX1.5463C	\$ 2,070
2		SPX2463C	\$ 2,070
3		SPX3463C	\$ 2,070
5		SPX5463C	\$ 2,070
7 – 1/2		SPX7463C	\$ 2,090
10		SPX10463C	\$ 2,100
15		SPX15463C	\$ 2,200
20		SPX20463C	\$ 2,240
25		SPX25463C	\$ 2,380
30		SPX30463C	\$ 2,570
40		SPX40463C	\$ 2,660
50		SPX50463C	\$ 2,720

See Page 25 & 26 for Factory Modifications

Simplex Lift Station Pump Panels

Options

Description	Option Code	List Price
Dead-front Enclosure Construction Tamper-proof design with Swing-out inner door and Lockable outer door	A	\$ 620
NEMA/UL Type 4 Enclosure Steel, Water & Dust-Tight, Indoor/Outdoor use	B	\$ 620
NEMA/UL Type 4X Fiberglass-Reinforced Polyester, Water & Dust-Tight, Indoor/Outdoor use, Corrosion-Resistant	C	\$ 980
NEMA/UL Type 4X 304 Stainless Steel, Water & Dust-Tight, Indoor/Outdoor, Corrosion-Resistant	D	\$ 1,600
Anti-Condensation Cabinet Heater 100 Watt, Fan-Driven, with integral adjustable thermostat	E	\$ 780
Elapsed Hour Meter 99999.9 Hours, Non-Reset, door mounted	F	\$ 320
Pump Running Indicating Light Green Lens, door mounted	G	\$ 200
Auxiliary Contacts 1-N.O./1-N.C. for remote monitoring of pump status	H	\$ 130
Motor Seal Failure Indicating Light Amber Lens, door mounted – Option requires Moisture Detecting Relay	I	\$ 200
Moisture Detecting Relay Relay Monitors a Seal Failure condition in the motor. Unless otherwise specified, the standard design will not shut-down pump.	J	Call for quote

Simplex Lift Station Pump Panels

Options

Description	Option Code	List Price
Motor Over-Temperature Shutdown Terminal Block for thermal switch in motor. Motor shutdown with auto reset	K	\$ 80
Motor Over-Temperature Indicating Light Relay and Red Indicating Light, door mounted, auto reset	L	\$ 400
Time Delay Relay Solid State, Multi-Function (on-delay, off-delay, single-shot, recycling)	M	\$ 450
Phase & Voltage Monitor Protection against Low & High Voltage, Unbalance, Phase Loss & Reversal	N	\$ 630
Surge/Lightning Arrester	O	\$ 360
High Water Alarm Beacon Light NEMA type 4X, Top mounted, Red Beacon, Tamper-proof, Halogen Lamp	P	\$ 340
High Water Alarm Horn NEMA type 4X, Side mounted, 103dB @ 10 Ft., adjustable output, with silencing pushbutton	Q	\$ 730
High Water Alarm Dry-Contact 1-N.O. Contact for remote monitoring of alarm status	R	\$ 230
Convenience Receptacle GFCI, 120V, 15 Amp, with weather-proof cover	S	\$ 790
Intrinsically Safe Relay: Interfaces with on/off floats Note: A separate ISR is required for High or Low Water Alarm	T	\$ 900
Auxiliary Control Relay	U	\$ 230
Push-to-Test Pilot Light	V	\$ 320

Duplex Lift Station Pump Panels

Product Description

Duplex Lift Station Pump Control Panels are designed to control the level in a municipal or industrial de-watering Lift Station housing two pumps.

When the level rises to a predetermined level, as sensed by an external level sensor (ie: float switch), the "lead pump" is turned on first. As the level recedes to a predetermined level, as sensed by a level sensor, the lead pump is turned off and automatic alternation is accomplished.

In the event that the level continues to rise beyond the capacity of the lead pump, the "lag" pump is turned on, and both pumps will run simultaneously until the level recedes to the pumps off level as sensed by a level sensor.

Typical applications include sewage lift stations, storm drain lift station, or any installation where de-watering is required.

A "Duplex" panel consist of two across-the-line combination motor starters which provide protection against short circuit faults, motor overload faults, motor disconnecting means, and means to automatically turning the pump motors on/off.

Applied Motor Controls' Duplex Lift Station Pump Panels can be designed to incorporate a wide selection of power and control options meant to enhance the protection and performance of the pumps, or to meet the most demanding specifications.

Standard Features

- UL 508 Listed Industrial Control serialized label
- UL type 3R Outdoor Steel Enclosure Fully gasketed hinged door with provision for padlocks, and top & bottom brackets for wall or pole mounting
- Gray powder-coating finish suitable for use in harsh environments
- Power Terminal Block for termination of supply cables
- (2) Molded Case Circuit Breakers with Thermal-Magnetic Trip (Optional Fusible Switch with Fuses available)
- (2) External Handle mechanisms for Circuit Breakers. Handle features provisions for up to 3 padlocks when in the "off", and prevents door opening when in the "on" position
- (2) Full Voltage Magnetic Motor Starters with 120VAC coil
- (2) Solid State Overload Relays with adjustable trip point and inherent protection against loss of phase and unbalance
- 120V Control Circuit Transformer with primary & secondary protective fuses
- Solid State Duplex Alternator
- (2) Hand-Off-Auto Selector Switches
- Terminal Blocks for three remote Float Switches: Pumps Off, Lead Pump On, Lag Pump On

Built Right and On-Time...Every Time!

Duplex Lift Station Pump Panels

3 Phase Motor			
Motor Voltage	Maximum Horse Power	Part Number	List Price
230V 60HZ	1	DPX1233C	\$ 4,880
	1 – 1/2	DPX1.5233C	\$ 4,880
	2	DPX2233C	\$ 4,880
	3	DPX3233C	\$ 4,940
	5	DPX5233C	\$ 4,940
	7-1/2	DPX7233C	\$ 5,090
	10	DPX10233C	\$ 5,090
	15	DPX15233C	\$ 5,250
	20	DPX20233C	\$ 5,920
	25	DPX25233C	\$ 5,990
	460V 60HZ	1	DPX1463C
1 – 1/2		DPX1.5463C	\$ 4,880
2		DPX2463C	\$ 4,880
3		DPX3463C	\$ 4,880
5		DPX5463C	\$ 4,880
7 – 1/2		DPX7463C	\$ 4,940
10		DPX10463C	\$ 4,940
15		DPX15463C	\$ 5,090
20		DPX20463C	\$ 5,090
25		DPX25463C	\$ 5,250
30		DPX30463C	\$ 5,250
40		DPX40463C	\$ 5,920
50		DPX50463C	\$ 5,990

See Page 29 & 30 for Factory Modifications

Duplex Lift Station Pump Panels

Options

Description	Option Code	List Price
Dead-front Enclosure Construction Tamper-proof design with Swing-out inner door and Lockable outer door	A	\$ 620
NEMA/UL Type 4 Enclosure Steel, Water & Dust-Tight, Indoor/Outdoor	B	\$ 620
NEMA/UL Type 4X Enclosure Fiberglass-Reinforced Polyester, Water & Dust-Tight, Indoor/Outdoor, Corrosion-Resistant	C	\$ 1,200
NEMA/UL Type 4X Enclosure 304 Stainless Steel, Water & Dust-Tight, Indoor/Outdoor, Corrosion-Resistant	D	\$ 2,200
Cabinet Heater 100 Watt, Fan-Driven, with integral adjustable thermostat	E	\$ 760
Elapsed Hour Meters (2) 99999.9 Hours, Non-Reset, door mounted	F	\$ 640
Pump Running Indicating Lights (2) Green Lens, door mounted	G	\$ 400
Auxiliary Contacts (2) 1-N.O./1-N.C. for remote monitoring of pump status	H	\$ 260
Motor Seal Failure Indicating Lights (2) Amber Lens, door mounted – Option requires Moisture Detecting Relays	I	\$ 400
Moisture Detecting Relays (2) Relays Monitor a Seal Failure condition in the motor (s). Unless otherwise specified, the standard design will not shut-down pump (s).	J	Call for quote

Duplex Lift Station Pump Panels

Options

Description	Option Code	List Price
Motor Over-Temperature Shutdown (2) Terminal Blocks for thermal switches in motor. Shutdown with auto reset	K	\$ 150
Motor Over-Temperature Indicating Lights (2) Relays and Red Indicating Lights, door mounted, auto reset	L	\$ 790
Time Delay Relay Solid State, Multi-Function (on-delay, off-delay, single-shot, recycling)	M	\$ 450
Phase & Voltage Monitor Protection against Low & High Voltage, Unbalance, Phase Loss & Reversal	N	\$ 650
Surge/Lightning Arrester	O	\$ 460
High Water Alarm Beacon Light NEMA type 4X, Top mounted, Red Beacon, Tamper-proof, Halogen Lamp	P	\$ 340
High Water Alarm Horn NEMA type 4X, Side mounted, 103dB @ 10 Ft., adjustable output, with silencing pushbutton	Q	\$ 730
High Water Alarm Dry-Contact 1-N.O. Contact for remote monitoring of alarm status	R	\$ 230
Convenience Receptacle GFCI, 120V, 15 Amp, with weather-proof cover	S	\$ 790
Intrinsically Safe Controller Interfaces with up to 5 Float Switches, integral alternator	T	\$ 2,500
Auxiliary Control Relay	U	\$ 230
Push-to-Test Pilot Light	V	\$ 320

Technical Information

Installation & Maintenance Instructions

Before Installing

1. Check cabinet and parts for any potential shipping damage
2. If any damage is observed, report immediately to the delivering carrier and file a freight claim. If possible take photographs as evidence of the damage
3. For any repair or replacement, contact Applied Motor Controls' home office
4. Do not return panel or parts unless written authorization is provided

Installation

1. Fasten cabinet to a solid mounting surface, and level the panel to allow for proper operation of its door
2. When conduit enters through the top, a properly sized and sealed conduit hub must be used to prevent leakage into the cabinet interior
3. Check supply power and confirm that it matches the panel and motor voltage
4. **INSPECT AND TIGHTEN ALL ELECTRICAL CONNECTIONS BEFORE ENERGIZING PANEL. FOLLOW THE TORQUE VALUES GIVEN FOR EACH TERMINAL/DEVICE. DO NOT OVER-TIGHTEN CONNECTIONS**
5. Terminate power supply cable at line terminal of main disconnect. Measure line-to-line and line-to-ground voltage values
6. Prior to connecting the motor cables, test the motor starter operation. Close the panel door and turn the power on, then turn the Hand/off/Auto to the "hand" mode. The motor starter should energize and close.
7. If motor starter does not energize, check for power continuity, blown fuses, and check starter coil voltage. Call the factory for technical support if necessary.
8. Tighten line and load cables according to the given torque values to prevent over-heating
9. Use 75°C copper cable only
10. Follow motor manufacturer's instructions for proper grounding of motor cables
11. Operate disconnect handle mechanism on the door to insure that interlock mechanism operates properly and it prevents door from opening when the handle is in the ON position
12. If an overload relay with adjustable trip point has been provided, set the trip point to match the Full Load Amps shown on the motor data nameplate

Maintenance

1. **RISK OF ELECTRICAL SHOCK** – More than one disconnect may be required to de-energized the equipment before servicing
2. Inspect panel periodically to insure that all moving parts operate freely
3. Interior should be kept clean. Excess dust, insects, debris, and foreign materials must be removed routinely
4. Inspect magnetic contactor contact points for wear at least once every six months. Worn contact points must be replaced. Contact points can be cleaned with an appropriate cleaner, but must never be filed
5. Visually inspect all cable terminations. Discoloring of any terminal or wire indicates a loose connection
6. **TIGHTEN ALL CONNECTIONS TO PREVENT CABLE AND TERMINAL OVERHEATING**

Replacement Parts

1. When replacement of any part is necessary, the replacement part must be of the same electrical ratings and characteristics

Technical Information

Sample Specification

Across the Line Pump Control Panel, Fused Type

1. Construction

1.1 Enclosure

The pump control panel shall be housed in a NEMA & UL rated type 3R outdoor enclosure fabricated from 14 gauge galvanized steel with an ANSI 49 dark gray powder coating finish inside and out.

The hinged door shall feature provisions for padlocks. Locking of the enclosure shall be responsibility of the owner. All door mounted devices shall be labeled and identified by engraved nameplates. A warning sign stating "DANGER – Disconnect all sources of power before opening door" shall be installed on the door.

1.2 Back-panel

The pump control panel enclosure shall feature a removable back-panel fabricated from 12 gauge steel with a white polyester finish. All components shall be fastened to the back-panel using machine screws. Self-tapping screws are not acceptable. All devices shall be clearly labeled and identified in accordance with the schematic ladder diagram

2. Power Circuit Equipment

2.1 Main Disconnect Switch

The pump motor circuit shall be protected by a properly sized Fusible Disconnect Switch. The disconnect switch shall be operated by an external handle mechanism interlocked to the door to prevent opening when in the panel is energized. The handle mechanism shall have its ON-OFF positions clearly labeled, and shall feature provisions for padlocking in the OFF position.

2.2 Power Fuses

Time-Delay Dual-Element Current-Limiting Class-J fuses shall provide protection against short-circuit faults. Each Fuse shall be sized at 125% of motor full load amps. The AC interrupting rating shall be 300,000 Amps RMS Sym.

2.3 Magnetic Motor Starter

The pump control panel shall feature an appropriately rated full voltage non-reversing across-the-line magnetic motor starter with a coil rated 120 volts. The motor starter shall feature a solid state overload relay (heaters not acceptable) with Class 10 trip characteristics and an adjustable trip point. Power wiring shall be rated at 600 volts rated at 75°C.

3. Control Circuit Equipment

3.1 Control Circuit Transformer

An Industrial Control Transformer shall provide 120VAC power to all control circuits. The primary and secondary side shall be protected by time-delay fuses. The VA rating of the transformer shall be sufficient to operate all the devices plus 10% spare capacity.

3.2 Control Circuit Wiring

Control circuit wiring inside the panel shall be copper 16 AWG minimum, type MTW or THW, rated for 300 volts. Conductors shall be numbered at each end using wire markers.

3.3 Pump Mode Switch

The panel shall have a three position Hand-Off-Automatic selector switch to select the operating mode for the pump. In the Hand position, the pump is called to run manually. In the Automatic position, the pump will be called to run by a signal from a remote control device. In the Off position, the pump will be turned off.

3.4 Terminal Blocks

All wiring within the pump control panel must be routed inside wiring ducts and terminated at clearly labeled terminal blocks. Terminal blocks shall be rated at 600V

4. Codes and Standards

The pump control panel shall bear a serialized UL 508 Industrial Control label.

Technical Information

Sample Schematics

Across-the-Line Pump Panel
Fusible Switch Type with Control Circuit Transformer and H/O/A Switch

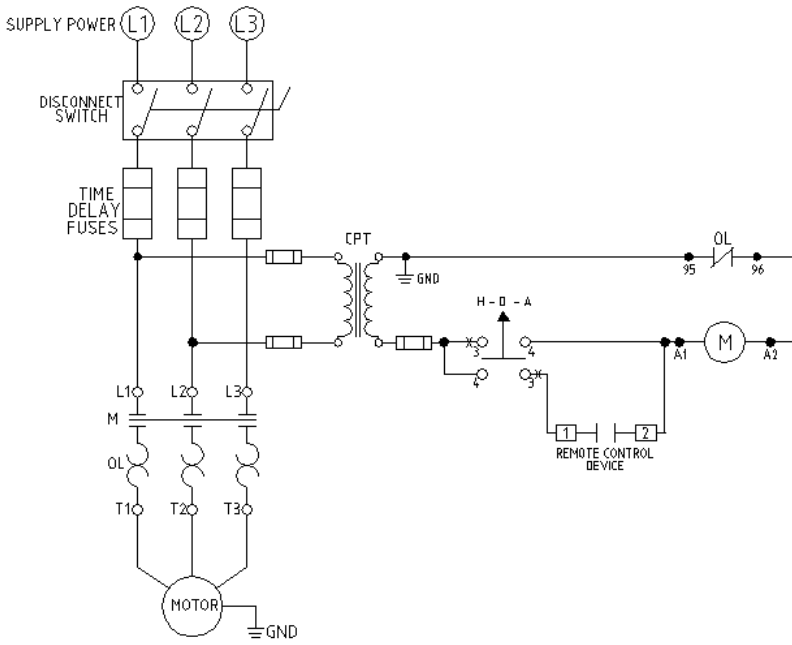

Standard Duplex Booster Pump Panel

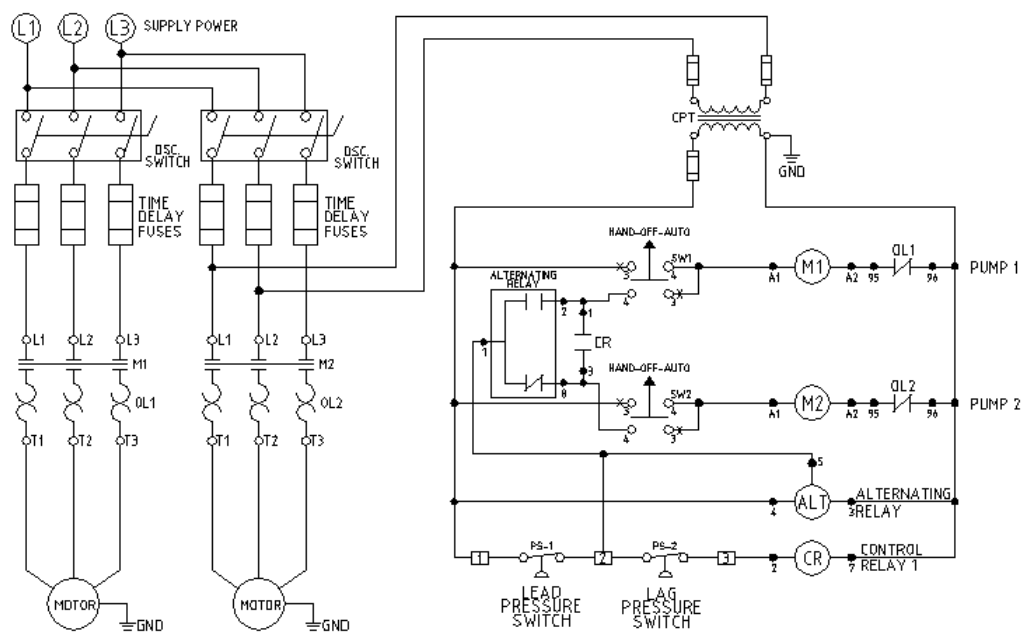

Technical Information

Enclosure Ratings

UL and NEMA are standard writing organizations commonly recognized in North America. Their ratings are based on similar application descriptions and expected performance. UL requires independent testing by qualified evaluators. NEMA, on the other hand, does not require independent testing and leaves compliance completely up to manufacturer.

Standards

Enclosure Rating	NEMA (Standard 250)	UL (UL50 and UL508)
Type 1	Enclosures intended for indoor use primarily to provide a degree of protection against contact with the enclosed equipment or locations where unusual service conditions do not exist.	Indoor use primarily to provide protection against contact with the enclosed equipment and against a limited amount of falling dirt
Type 3	Enclosures intended for outdoor use primarily to provide a degree of protection against windblown dust, rain, and sleet. Undamaged by the formation of ice on the enclosure.	Outdoor use to provide a degree of protection against windblown dust and wind-blown rain. Undamaged by the formation of ice on the enclosure.
Type 3R	Enclosures intended for outdoor use primarily to provide a degree of protection against falling rain and sleet. Undamaged by the formation of ice on the enclosure.	Outdoor use to provide a degree of protection against falling rain. Undamaged by the formation of ice on the enclosure.
Type 4	Enclosures intended for indoor or outdoor use primarily to provide a degree of protection against windblown dust and rain, splashing water, and hose-directed water. Undamaged by the formation of ice on the enclosure.	Either indoor or outdoor use to provide a degree of protection against falling rain, splashing water, and hose-directed water. Undamaged by the formation of ice on the enclosure.
Type 4X	Enclosures intended for indoor or outdoor use primarily to provide a degree of protection against corrosion, windblown dust and rain, splashing water, and hose-directed water. Undamaged by the formation of ice on the enclosure.	Either indoor or outdoor use to provide a degree of protection against falling rain, splashing water, and hose-directed water. Undamaged by the formation of ice on the enclosure. Resists corrosion.
Type 12	Enclosures intended for indoor use primarily to provide a degree of protection against dust, falling dirt, and dripping non-corrosive liquids.	Indoor use to provide a degree of protection against dust, dirt, fiber flyings, dripping water, and external condensation of non-corrosive liquids.



Built Right and On-Time...Every Time!

Applied Motor Controls, Ltd.
319 Wolfe Road
San Antonio, TX 78216 • USA
Tel: (210) 524-1050
Fax: (210) 524-1044
www.amclp.com